

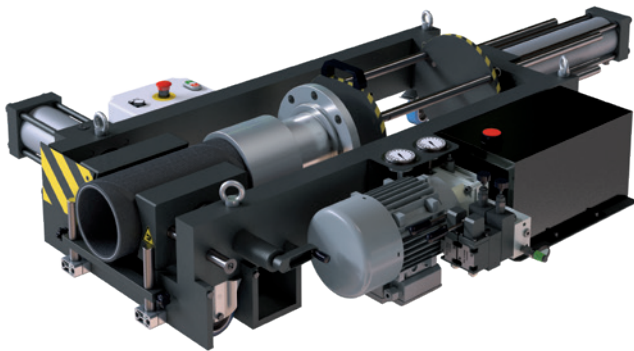

KuriCrimpTM

Assembly System

Conqueror[®] Concrete Hose with Conqueror[®] Couplings Assembly Manual



FEATURING

CONQUEROR[®]

Industrial Hose



KURIYAMA
OF AMERICA, INC.

Since 1968

kuriyama.com

CONQUEROR®

Concrete Hose Assembly Guidelines

The Conqueror® Concrete Hose System consists of a complete line of hose, fittings and clamps; specially designed by Alfagomma to work together, ensuring complete product compatibility. The line also includes a complete assembly process, utilizing KuriCrimp™ hose processing equipment, specially modified by O+P to work with the Conqueror® Hose system. The following procedures are designed to help ensure proper assembly of Conqueror concrete hose and couplings.

FABRICATION EQUIPMENT

Concrete hose couplings pose unique challenges during assembly due to their robust nature and large shank OD's. Therefore, the assembler must verify suitability of hose saw, pusher and crimper prior to beginning the assembly process.

The following equipment has been validated for use with Conqueror Concrete Hose and Couplings. With proper testing other equipment may also be considered acceptable.

Item	Part Number	Description	Max. Hose Size (in)
Hose Saw	KCS-TF5DI-230/3	10 HP (230 V) 3 PH Saw	5
Hose Pusher	KPUSH22-CON	11 ton, 3 HP (110 V) 1 PH Pusher	8
Hose Crimper	KC4-V160-230/3	386 ton 10 HP, (230 V) 3 PH Crimper	6

FABRICATION PROCESS

Pre Fabrication Steps

1. Ensure proper safety equipment, such as gloves and protective eyewear, are used.
2. Verify customer assembly requirements: including hose type, hose ID, hose length; and fitting type(s).
3. Establish quality control (QC) document with assembly requirements, date, operator info, lot number as well as any other relevant or required information.

Hose Cutting and Preparation

Reference Hose Saw manual to ensure proper saw set-up procedures have been followed and proper cutting conditions are in place.

4. Determine customer's required assembly length, measure and cut hose; ensuring hose end is cut square and inside of hose is cleaned of debris.
5. Using a caliper, measure hose wall thickness at four, equidistant points and average, to determine wall thickness value. Record measurements and average value on quality control document.
6. Reference the Conqueror Concrete Hose Crimp Specification Chart (pages 3–5) to determine appropriate crimp diameter based on hose wall thickness value.
7. Record determined crimp diameter on QC document.



COUPLING INSERTION AND DETERMINING INSERTION DEPTH:

Reference Hose Pusher manual to ensure proper pusher set-up procedures have been followed and proper pushing conditions are in place.

- Determine the concrete coupling insertion depth by laying the fitting next to the end of the hose, aligning the top of the coupling ferrule with the end of the hose. Using a white marker, draw a line on the hose at the spot where it aligns with the bottom of the ferrule. This line represents the fitting insertion depth, and serves as a visual check of whether the fitting is fully inserted, or “bottomed out”, during the insertion process.

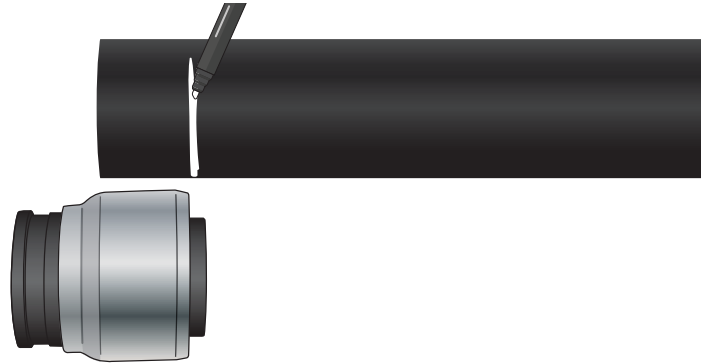

- If using the KPUSH22-CON, ensure secure installation of appropriate insertion mandrel and place hose coupling over insertion mandrel.
- If using the KPUSH22-CON, ensure secure installation of appropriate hose jaws, and insert hose between hose jaws. Begin closing hose jaws, making adjustment to horizontally align hose with coupling.
- Slowly and fully insert coupling into hose without damaging hose tube. If coupling appears to be misaligned while inserting, make small adjustments to hose clamp as needed to improve hose alignment with coupling.

HOSE CRIMPING:

Reference Crimper manual to ensure proper crimper set-up procedures have been followed and proper crimping conditions are in place.

- Refer to Conqueror® Concrete Hose Crimp Specification Chart to determine appropriate crimp diameter and corresponding die set.
- Insert appropriate crimp dies into crimper and set crimper to appropriate crimp diameter.
- Crimp hose using determined crimp diameter.
- Measure crimp diameter of finished assembly and compare to target diameter. Make sure to measure in-between the ridges on the ferrule caused by the crimping process.
- If necessary, re-crimp hose until appropriate crimp diameter is obtained.
- Record final crimp diameter information.
- Repeat steps 4 through 16 for opposite end of assembly, if necessary.

Because we continually examine ways to improve our products, we reserve the right to alter specifications or discontinue products without prior notice.



T74SAA Series with CHC Couplings

Textile Reinforced Concrete Pumping Hose



CHC-CA Series



CHC-VS Series

Fitting Series	Hose Size ID (in)	Ferrule Crimping Length	Crimping Parameters Final Crimping Diameter				
			Hose Thickness (in)	Crimping Diameter (in)	Hose Thickness (mm)	Crimping Diameter (mm)	Die Size (mm)
CHC-CA200 CHC-VS200 CHC-MP200	2	Full	0.344	3.11	8.75	79.1	77
			0.354	3.13	9.00	79.5	77
			0.364	3.15	9.25	79.9	77
			0.374	3.16	9.50	80.3	77
			0.384	3.17	9.75	80.6	77
			0.394	3.19	10.00	81.0	77
			0.403	3.20	10.25	81.4	77
			0.413	3.22	10.50	81.8	77
			0.423	3.23	10.75	82.1	77
			0.433	3.25	11.00	82.5	77
CHC-CA250 CHC-VS250	2 1/2	Full	0.443	3.26	11.25	82.9	77
			0.344	3.59	8.75	91.3	90
			0.354	3.60	9.00	91.6	90
			0.364	3.62	9.25	92.0	90
			0.374	3.63	9.50	92.3	90
			0.384	3.65	9.75	92.7	90
			0.394	3.66	10.00	93.0	90
			0.403	3.68	10.25	93.4	90
			0.413	3.69	10.50	93.7	90
			0.423	3.70	10.75	94.1	90
CHC-CA300 CHC-VS300 CHC-MP300	3	Full	0.433	3.71	11.00	94.4	90
			0.443	3.73	11.25	94.8	90
			0.443	4.32	11.25	109.8	106
			0.452	4.33	11.50	110.1	106
			0.462	4.35	11.75	110.5	106
			0.472	4.36	12.00	110.8	106
			0.482	4.37	12.25	111.2	111
			0.492	4.39	12.50	111.5	111
			0.502	4.40	12.75	111.9	111
			0.512	4.41	13.00	112.2	111
CHC-CA400 CHC-VS400 CHC-MP400 CHC-SF400 CHC-SM400	4	Full	0.521	4.43	13.25	112.6	111
			0.531	4.44	13.50	112.9	111
			0.541	4.46	13.75	113.3	111
			0.462	5.61	11.75	142.5	139
			0.472	5.62	12.00	142.8	139
			0.482	5.63	12.25	143.2	139
			0.492	5.65	12.50	143.5	139
			0.502	5.66	12.75	143.9	139
			0.512	5.67	13.00	144.2	144
			0.521	5.69	13.25	144.6	144
0.531	5.70	13.50	144.9	144			
0.541	5.72	13.75	145.3	144			
0.551	5.73	14.00	145.6	144			
0.561	5.75	14.25	146.0	144			

Because we continually examine ways to improve our products, we reserve the right to alter specifications or discontinue products without prior notice.



T740AA Series with CHC Couplings
Wire Reinforced Concrete Pumping Hose



CHC-CA Series



CHC-VS Series

Fitting Series	Hose Size ID (in)	Ferrule Crimping Length	Crimping Parameters Final Crimping Diameter				
			Hose Thickness (in)	Crimping Diameter (in)	Hose Thickness (mm)	Crimping Diameter (mm)	Die Size (mm)
CHC-CA200 CHC-VS200 CHC-MP200	2	Full	0.315	3.07	8.00	78.0	77
			0.325	3.08	8.25	78.4	77
			0.334	3.10	8.50	78.8	77
			0.344	3.11	8.75	79.1	77
			0.354	3.13	9.00	79.5	77
			0.364	3.15	9.25	79.9	77
			0.374	3.16	9.50	80.3	77
			0.384	3.17	9.75	80.6	77
			0.394	3.19	10.00	81.0	77
			CHC-CA250 CHC-VS250	2 1/2	Full	0.394	3.66
0.403	3.68	10.25				93.4	90
0.413	3.69	10.50				93.7	90
0.423	3.70	10.75				94.1	90
0.433	3.72	11.00				94.4	90
0.443	3.73	11.25				94.8	90
0.452	3.74	11.50				95.1	90
0.462	3.76	11.75				95.5	90
0.472	3.77	12.00				95.8	90
CHC-CA300 CHC-VS300 CHC-MP300	3	Full				0.433	4.35
			0.443	4.36	11.25	110.9	106
			0.452	4.38	11.50	111.3	111
			0.462	4.39	11.75	111.6	111
			0.472	4.41	12.00	112.0	111
			0.482	4.42	12.25	112.4	111
			0.492	4.44	12.50	112.8	111
			0.502	4.45	12.75	113.1	111
			0.512	4.47	13.00	113.5	111
			CHC-CA400 CHC-VS400 CHC-MP400 CHC-SF400 CHC-SM400	4	Full	0.423	5.59
0.433	5.61	11.00				142.5	139
0.443	5.62	11.25				142.9	139
0.452	5.64	11.50				143.3	139
0.462	5.65	11.75				143.6	139
0.472	5.67	12.00				144.0	144
0.482	5.68	12.25				144.4	144
0.492	5.70	12.50				144.8	144
0.502	5.71	12.75				145.1	144
0.512	5.73	13.00				145.5	144
0.521	5.74	13.25				145.9	144
0.531	5.76	13.50				146.3	144
0.541	5.77	13.75				146.6	144
0.551	5.79	14.00				147.0	144

Because we continually examine ways to improve our products, we reserve the right to alter specifications or discontinue products without prior notice.



T740AA Series with CHC Couplings
Wire Reinforced Concrete Pumping Hose



CHC-CA Series



CHC-VS Series

Fitting Series	Hose Size ID (in)	Ferrule Crimping Length	Crimping Parameters Final Crimping Diameter				
			Hose Thickness (in)	Crimping Diameter (in)	Hose Thickness (mm)	Crimping Diameter (mm)	Die Size (mm)
CHC-CA500 CHC-VS500 CHC-VS550 CHC-MP500 CHC-SF500 CHC-SM500	5	Full	0.462	6.67	11.75	169.5	166
			0.472	6.68	12.00	169.8	166
			0.482	6.70	12.25	170.2	166
			0.492	6.71	12.50	170.5	166
			0.502	6.73	12.75	170.9	166
			0.512	6.74	13.00	171.2	166
			0.521	6.75	13.25	171.6	166
			0.531	6.77	13.50	171.9	166
			0.541	6.78	13.75	172.3	166
			0.551	6.79	14.00	172.6	166
			0.561	6.81	14.25	173.0	166
			0.571	6.82	14.50	173.3	166
			0.581	6.84	14.75	173.7	166
			0.590	6.85	15.00	174.0	166
			0.600	6.86	15.25	174.4	166
CHC-VS600 CHC-SF600 CHC-SM600	6	Full	0.580	7.86	14.75	199.7	190
			0.590	7.87	15.00	200.0	190
			0.600	7.88	15.25	200.4	190
			0.610	7.90	15.50	200.7	190
			0.620	7.91	15.75	201.1	190
			0.629	7.92	16.00	201.4	190
			0.639	7.94	16.25	201.8	190
			0.649	7.95	16.50	202.1	190
			0.659	7.97	16.75	202.5	190
			0.669	7.98	17.00	202.8	190
0.679	8.00	17.25	203.2	190			

Note: 6" T740AA Conqueror Hose and Fittings would use KC4-V250-230/3 crimper.

Because we continually examine ways to improve our products, we reserve the right to alter specifications or discontinue products without prior notice.

TESTING PROCESS

While various customer requirements vary, a predetermined level of validation testing should be performed to ensure the safety of the concrete hose assemblies. The assembler should discuss testing requirements with their customer prior to assembly.

Reprinted from NAHAD Industrial Hose Fabrication Guidelines (Version 3, July 2020)

F4.1 Hydrostatic Proof Pressure Tests (Non-destructive)

A proof test is typically conducted for 5 minutes under pressure at one and a half times (1.5x) the working pressure for new or used assemblies.

Proof or hydrostatic testing refers to testing that “proves” the finished hose assembly meets the pressure rating required by the application for which it will be used, and that the end fittings have been correctly fitted and the assembly is leak free.

- For assembly testing, the rating of the component (hose or coupling) with the lowest rated working pressure determines the working pressure of the assembly.

Pressurize hose to 10 psi for 60 seconds prior to conducting the hydrostatic test.

- Hose assembly should be secured in an encapsulated tank that will withstand the pressure; at a minimum, make sure that the hose is sufficiently shielded during pressure testing to stop a coupling in case of a coupling blow-off.
- If applicable, secure hose with steel rods or straps close to each end and at ten-foot intervals along the length of the hose. This will prevent it from “whipping” if a failure occurs. The securing rods or straps must be anchored firmly to the test structure, but should not contact the hose. The hose must be free to move slightly when pressure is applied.
- Hoses must be properly cleaned prior to inspection and testing; this will prevent unexpected reactions between conveyants and the test media.
- Always wear safety glasses, gloves, and protective clothing to protect from leaks or high pressure spray. Also, use shields to protect people in the work area in the event of a hose burst, spray, or coupling blow-off.
- It is recommended to never stand in front of, over, or behind the ends of a hose assembly during pressure testing.

All hydrostatic testing should be conducted with liquid media (preferably water). Pneumatic testing with gasses such as air or nitrogen is prohibited. The energy stored when pressure testing with gasses creates a very dangerous system, where product failure may cause injury or death.

EQUIPMENT:

- Hand pump, a power driven hydraulic pump, or an accumulator system
- Outlet valve
- Test tank (preferred, if applicable)
- Unless otherwise stated by the purchaser, the test medium should be water.

THE FOLLOWING TESTING PROCEDURE IS RECOMMENDED:

1. Lay the hose out straight whenever practical, slightly elevating one end to ensure trapped air is expelled, allowing space for elongation under pressure, preferably on supports to allow free movement under pressure; take particular care to ensure that all trapped air is released from the hose. This is a critical safety measure because expansion of air compressed in the hose, when suddenly released by bursting or other failure, might result in a serious accident.
2. For reference, mark a line behind the coupling which is at the end of the ferrule, clamp, band, etc.
3. Then gradually raise the pressure to the desired pressure rating. Hold the pressure for the time dictated by hose type and conduct a visual inspection. As the pressure is raised, watch for visual indications of permanent deformation, leakage, and coupling slippage. If any of these are noted it is cause for rejection*. After the test is complete, relieve the test pressure before disconnecting the hose assembly from the test equipment and drain the water from the hose. The hose may be flushed with alcohol if all of the water must be removed.
4. When tested in accordance with the above, the assembly under test should be totally leak free for the duration of the test; leakage is defined as a continuous stream of water droplets emitted from a single or multiple locations.

**For industrial hose and depending on coupling design, a minimal amount of hose coupling slippage may be acceptable if the hose does not show any leakage at any time during the test; a second test is recommended in that case to confirm assembly integrity. Contact the manufacturer with any concerns.*

*** For further detail in regards to fabrication, crimping and testing details, please refer to the most recent edition of the NAHAD Guide for the fabrication of Industrial Hose Assemblies for reference.*



KURIYAMA
OF AMERICA, INC.

ALFAGOMMA®



AMERICAN CONCRETE
PUMPING ASSOCIATION

NAHAD
The Association for Hose
and Accessories Distribution

Because we continually examine ways to improve our products, we reserve the right to alter specifications or discontinue products without prior notice.

THE KURIYAMA NETWORK

Kuriyama's North American Operations comprise an integrated network of manufacturing and distribution facilities strategically located across the continent. This footprint supports a wide range of industrial and hydraulic hose and couplings products, and the capability to engineer custom solutions for demanding applications.

The Kuriyama Distribution Network serves the United States through five primary distribution centers totaling more than 700,000 square feet, including a state-of-the-art 329,000 square foot Central Distribution Center in Huntley, Illinois.

Our Manufacturing Network includes seven North American manufacturing and compounding facilities, producing thermoplastic industrial hose, hydraulic hose, high pressure spray hose, metal hose assemblies, NFPA 1961 fire hose and engineered tubing.



CORPORATE HEADQUARTERS

NORTH AMERICAN HEADQUARTERS

150 N Martingale Road, Suite 900
Schaumburg, IL 60173
☎ (847) 755-0360
🌐 kuriyama.com
✉ customerservice@kuriyama.com

CANADA HEADQUARTERS

KURI TEC CORPORATION
140 Roy Boulevard
Brantford, ON, Canada N3R 7K2
☎ (519) 753-6717
🌐 Kuritec.com
✉ sales@kuritec.com

MEXICO HEADQUARTERS

KURIYAMA DE MÉXICO
Av. José Palomo Martínez # 520-20
Parque Industrial Omolap
Apodaca, N.L. 66633, México
☎ +52 811 086 1870
🌐 Kuriyama.com.mx
✉ servicioalcliente@kuriyama.com

MANUFACTURING, COMPOUNDING & PRODUCTION

TIGERFLEX CORPORATION

1551 Pratt Blvd
Elk Grove Village, IL 60007
☎ (847) 640-8366

KURIYAMA CANADA MFG.

140 Roy Boulevard
Brantford, ON, Canada N3R 7K2
☎ (519) 753-6717
✉ sales@kuritec.com

ACCUFLEX INDUSTRIAL MFG.

760 Imperial Rd N
Guelph, ON, N1K 1Z3, Canada
☎ (519) 836-5460

KURITEC MANUFACTURING & KURIYAMA FIRE MFG.

2600 E. U.S. Highway 41
Attica, IN 47918
☎ (765) 764-6000
🏠 (765) 764-6001

HOSE TEC MANUFACTURING

2520 E. U.S. Highway 41
Attica, IN 47918
☎ (765) 762-5501 OR
☎ (800) 878-5501
🏠 (765) 762-5502 OR
🏠 (800) 879-8232

PIRANHA HOSE PRODUCTS

2500 Raymond Weigel St.
Cadillac, MI 49601
☎ (800) 250-5132 OR
☎ (231) 779-4390
🏠 (231) 779-4399

DISTRIBUTION CENTERS AND WAREHOUSES

USA CENTRAL DISTRIBUTION CENTER – HUNTLEY

14200 Commerce Court
Huntley, IL 60142
☎ (847) 755-0360

WEST COAST WAREHOUSE – RENO

12910 Old Virginia Road,
Suite 100
Reno, NV 89521
☎ (847) 755-0360

SOUTHWEST WAREHOUSE – HOUSTON

200 Portwall Street, Suite 100
Houston, TX 77029
☎ (847) 755-0360

NORTHEAST WAREHOUSE – CARLISLE

1600 Distribution Drive,
Building B
Carlisle, PA 17013
☎ (847) 755-0360

SOUTHEAST WAREHOUSE – ACWORTH

FORTNEY SALES CO., INC.
4221 Cantrell Road NW
Acworth, GA 30101
☎ (770) 427-6528
🏠 (770) 423-9249 OR
🏠 (800) 423-9249

CANADA CENTRAL DISTRIBUTION CENTER

KURI TEC CORPORATION
575 Jack Ross Ave.
Woodstock, ON N4V 1B6
☎ (519) 753-6717

MEXICO CENTRAL DISTRIBUTION CENTER

KURIYAMA DE MÉXICO
Av. José Palomo Martínez # 520-20
Parque Industrial Omolap
Apodaca, N.L. 66633, México
☎ +52 811 086 1870
✉ servicioalcliente@kuriyama.com